ARP

ROUND INSERT CUTTER
FOR DIFFICULT TO CUT MATERIALS



ARP

HIGH ACCURACY RUN-OUT PROVIDES EFFICIENT MACHINING

STRONG CLAMPING SYSTEM

A wide seating face and 2 side location faces prevent inserts from moving during cutting.

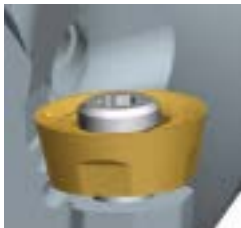

Easy indexing – No need to completely remove the clamping screw

OPTIMISED CHIP FLOW FOR LOW CUTTING RESISTANCE

Special rake face geometry on each section of the insert corresponds to the indexing position and therefore provides smooth chip flow for low cutting resistance at each index position.

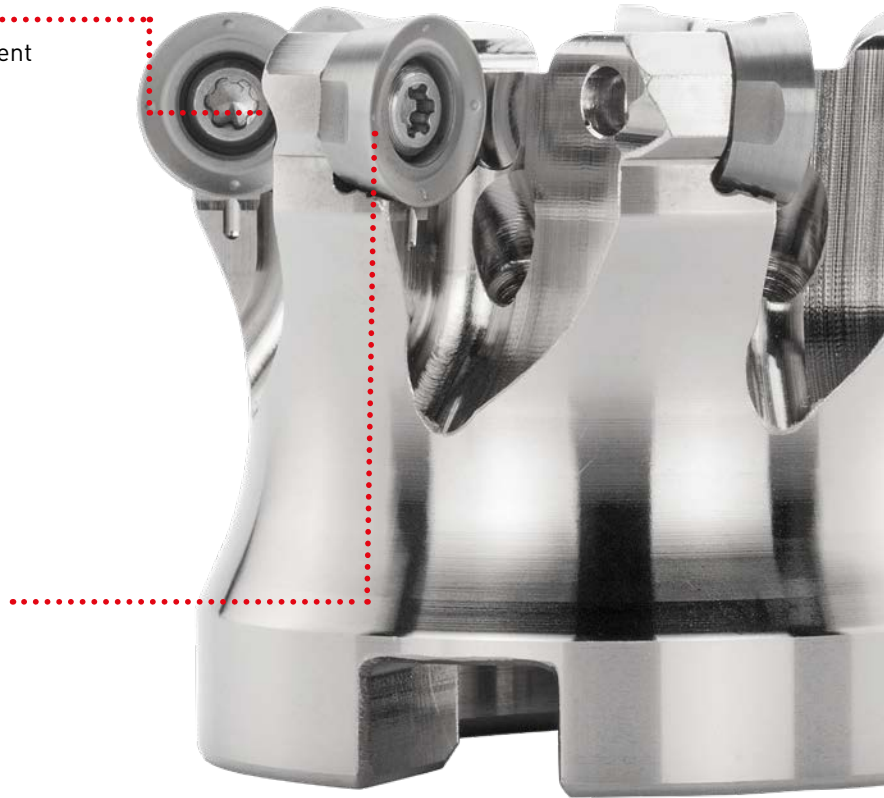

PRECISE INSERT POSITIONING PROVIDES RUN-OUT ACCURACY AND INCREASES TOOL LIFE

5 TOOTH CUTTER

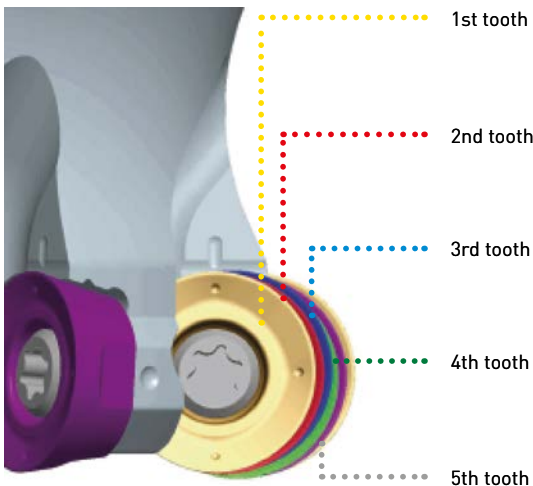

Highly accurate seating realises minimal change of position and provides run-out accuracy after indexing the inserts.

Compared to conventional tools:
Axial runout shows a 25 % improvement

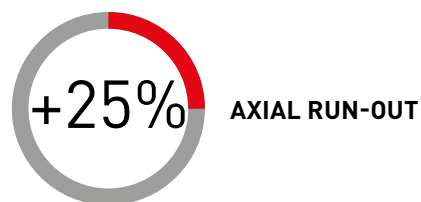

NEW INDEXING SEAT FACES

The new advanced indexing design, plus the variety of new grades available significantly increases the effectiveness of the ARP series while also maintaining stability and economy.

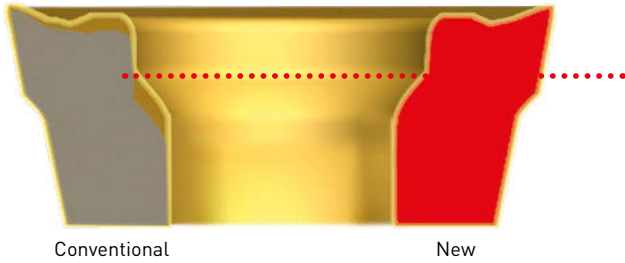

THICKER AND WIDER INSERT TO PREVENT CRACKING

In order to minimize sudden failure of the insert under difficult cutting conditions, the insert has been redesigned. Now incorporating a wider core and increased thickness.

LOW DEPTH OF CUT	HIGH DEPTH OF CUT

DESIGN

The design of the chipbreaker in combination with the reinforcement of the insert enables a significantly increased resistance to breakage.

SEATING FACES

Designed with 4 or 8 position indexing faces provides the optimum design depending on cutting requirements.

4 indexing seat faces = RPHT○○○○○○E4-○/RPMT○○○○○○E4-○
 8 indexing seat faces = RPMT○○○○○○E8-○

PREVENTING ROTATION

The use of the 4 or 8 position indexing faces also prevents rotation, thereby ensuring reliable clamping even under the toughest cutting conditions.

THE RAKE FACE DIRECTS CUTTING FORCES TOWARDS THE CENTRE

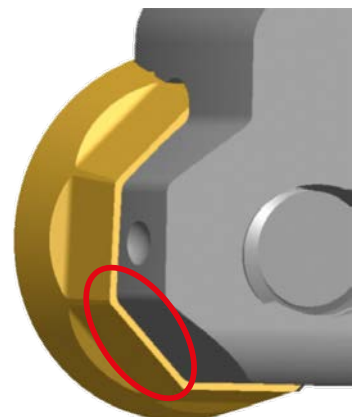
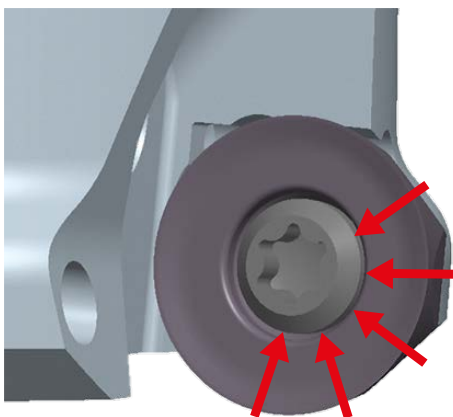

MP9140

PVD COATED GRADE FOR DIFFICULT TO CUT MATERIALS

SMOOTH COATING SURFACE PROVIDES EXCELLENT WELDING RESISTANCE

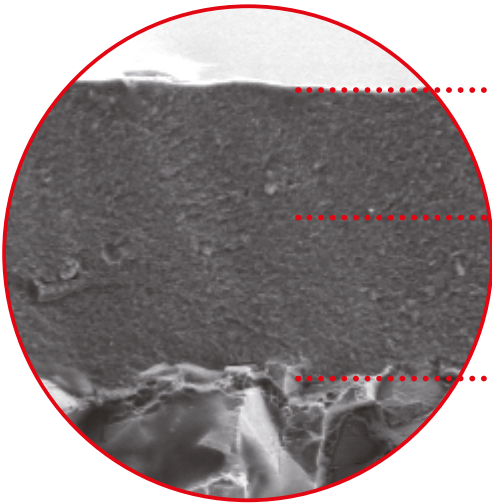

The smooth coating surface provides excellent welding resistance.

The high Al-rich AlTiN coating succeeds in dramatically improving wear and heat resistance.

Special cemented carbide substrate with improved fracture resistance.

APPLICATION RANGE

M	S
M10	S10
M20	S20
M30	S30
M40	S40

MC7020, MP7130, MP9130, MP9140

MC7020

Suppresses crater wear that occurs during high speed cutting. Achieves process stability in high efficiency machining conditions.

MP7130

For general milling of stainless steel.

MP9130

For interrupted and general milling of HRSA and titanium alloy.

MP9140

Focus on fracture resistance for difficult to cut Materials.

ARP5/6



MULTI FUNCTIONAL MILLING

M S

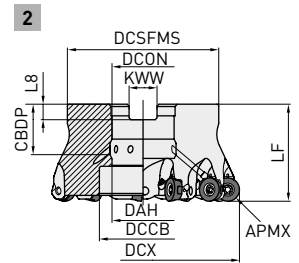
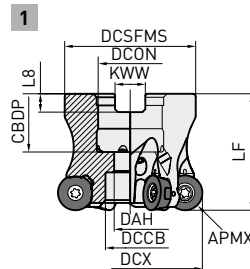

Right hand tool holder only.

GAMP :+4°
GAMF :-6°

DC	Set bolt	Geometry
Ø40	HSC08025H	
Ø50, Ø52, Ø63	HSC10030H	
Ø66, Ø80	HSC12035H	
Ø100	MBA16033H	

ARBOR TYPE

Order number	Stock	Cutting edge R	APMX	DCON	DCX	LF	RMPX	A1	AZ	WT	ZEFP	Type
ARP5P-040A05AR	●	5	5.0	16	40	40	2.8°	2.0	1.30	0.15	5	1
ARP5P-042A05AR	●		5.0	16	42	40	2.8°	2.5	1.40	0.16	5	1
ARP5P-050A06AR	●		5.0	22	50	40	2.9°	2.0	1.85	0.27	6	1
ARP5P-052A06AR	●		5.0	22	52	40	3.0°	2.5	2.00	0.29	6	1
ARP5P-063A07AR	●		5.0	22	63	40	3.0°	2.5	2.50	0.46	7	1
ARP5P-042A06AR	●		5.0	16	42	40	2.8°	2.5	1.40	1.6	6	1
ARP5P-050A07AR	●		5.0	22	50	40	2.9°	2.0	1.85	0.27	7	1
ARP5P-052A07AR	●		5.0	22	52	40	3.0°	2.5	2.00	0.29	7	1
ARP5P-063A08AR	●		5.0	22	63	40	3.0°	2.5	2.50	0.46	8	1
ARP6P-040A04AR	●		6	6.0	16	40	40	2.7°	2.0	1.15	0.15	4
ARP6P-050A05AR	●	6.0		22	50	40	2.9°	2.0	1.70	0.26	5	1
ARP6P-052A05AR	●	6.0		22	52	40	2.9°	2.5	1.80	0.28	5	1
ARP6P-063A06AR	●	6.0		22	63	40	3.1°	2.5	2.50	0.44	6	1
ARP6P-066X06AR	●	6.0		27	66	50	2.9°	2.5	2.50	0.64	6	1
ARP6P-080A08AR	●	6.0		27	80	50	2.3°	2.5	2.50	0.88	8	1
ARP6P-100B09AR	●	6.0		32	100	50	1.7°	2.5	2.50	1.47	9	2
ARP6P-050A06AR	●	6.0		22	50	40	2.9°	2.0	1.70	0.25	6	1
ARP6P-052A06AR	●	6.0		22	52	40	2.9°	2.5	1.80	0.27	6	1
ARP6P-063A07AR	●	6.0		22	63	40	3.1°	2.5	2.50	0.44	7	1
ARP6P-066X07AR	●	6.0	27	66	50	2.9°	2.5	2.50	0.64	7	1	
ARP6P-080A09AR	●	6.0	27	80	50	2.3°	2.5	2.50	0.88	9	1	
ARP6P-100B11AR	●	6.0	32	100	50	1.7°	2.5	2.50	1.45	11	2	



ARP5/6

MOUNTING DIMENSIONS

Order number	DCSFMS	CBDP	DAH	DCCB	KWW	L8
ARP5P-040A05AR	34	18	9	14	8.4	5.6
ARP5P-042A05AR	34	18	9	14	8.4	5.6
ARP5P-050A06AR	45	20	11	17	10.4	6.3
ARP5P-052A06AR	45	20	11	17	10.4	6.3
ARP5P-063A07AR	50	20	11	17	10.4	6.3
ARP5P-042A06AR	34	18	9	14	8.4	5.6
ARP5P-050A07AR	45	20	11	17	10.4	6.3
ARP5P-052A07AR	45	20	11	17	10.4	6.3
ARP5P-063A08AR	50	20	11	17	10.4	6.3
ARP6P-040A04AR	34	18	9	13.4	8.4	5.6
ARP6P-050A05AR	45	20	11	17	10.4	6.3
ARP6P-052A05AR	45	20	11	17	10.4	6.3
ARP6P-063A06AR	50	20	11	17	10.4	6.3
ARP6P-066X06AR	56	23	13	20	12.4	7
ARP6P-080A08AR	56	23	13	20	12.4	7
ARP6P-100B09AR	78	26	45	32	14.4	8
ARP6P-050A06AR	45	20	11	17	10.4	6.3
ARP6P-052A06AR	45	20	11	17	10.4	6.3
ARP6P-063A07AR	50	20	11	17	10.4	6.3
ARP6P-066X07AR	56	23	13	20	12.4	7
ARP6P-080A09AR	56	23	13	20	12.4	7
ARP6P-100B11AR	78	26	45	32	14.4	8



ARP5/6



MULTI FUNCTIONAL MILLING

M S

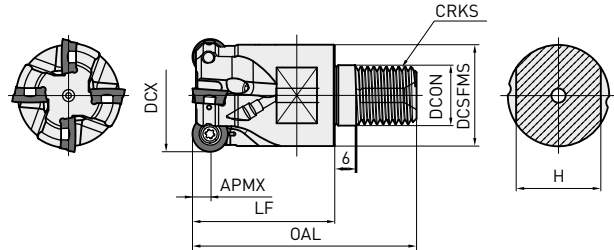

GAMP :+4°
GAMF :-6°--7°

SCREW IN TYPE

Order number	Stock	Cutting edge R	APMX	DCON	DCX	LF	H	RMPX	A1	AZ	WT	ZEFP
ARP5PR2502AM1235	●	5	5.0	12.5	25	140	19	1.8°	—	0.40	0.10	2
ARP5PR3203AM1640	●		5.0	17.0	32	150	24	1.9°	1.0	0.65	0.16	3
ARP5PR2503AM1235	●		5.0	12.5	25	180	19	1.8°	—	0.40	0.09	3
ARP5PR3204AM1640	●		5.0	17.5	32	200	24	1.9°	1.0	0.65	0.15	4
ARP6PR3202AM1640	●	6	6.0	17.0	32	150	24	2.0°	1.0	0.60	0.18	2
ARP6PR3203AM1640	●		6.0	17.0	32	150	24	2.0°	1.0	0.60	0.17	3
ARP6PR4003AM1640	●		6.0	17.0	40	150	24	2.7°	2.5	1.15	0.20	3
ARP6PR4004AM1640	●		6.0	17.0	40	200	24	2.7°	2.5	1.15	0.20	4



MOUNTING DIMENSIONS

Order number	DCON	DCX	DCSFMS	OAL	CRKS
ARP5PR2502AM1235	12.5	25	23.5	57	M12
ARP5PR3203AM1640	17.0	32	28.5	63	M16
ARP5PR2503AM1235	12.5	25	23.5	57	M12
ARP5PR3204AM1640	17.5	32	28.5	63	M16
ARP6PR3202AM1640	17.0	32	28.5	63	M16
ARP6PR3203AM1640	17.0	32	28.5	63	M16
ARP6PR4003AM1640	17.0	40	28.5	63	M16
ARP6PR4004AM1640	17.0	40	28.5	63	M16

ARP5/6



MULTI FUNCTIONAL MILLING

M S



GAMP :+4°
GAMF :-6°--7°

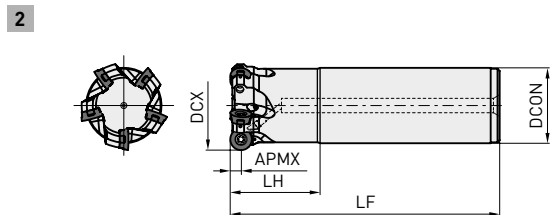
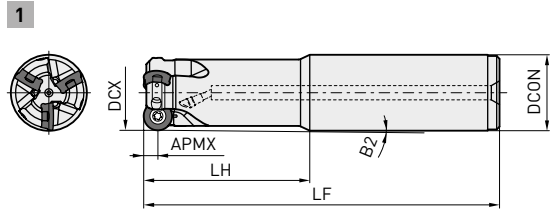

Right hand tool holder only.

SHANK TYPE

Order number	Stock	Cutting edge R	APMX	DCON	DCX	LF	LH	B2	RMPX	A1	AZ	WT	ZEFP	Type
ARP5PR2503SA25M	★	5	5.0	25	25	140	60	1.10°	1.8°	1.0	0.40	0.42	3	1
ARP5PR3204SA32M	★		5.0	32	32	150	70	0.92°	1.9°	1.0	0.65	0.77	4	1
ARP5PR2502SA25L	★		5.0	25	25	180	80	0.80°	1.8°	1.0	0.40	0.56	2	1
ARP5PR3203SA32L	★		5.0	32	32	200	120	0.51°	1.9°	1.0	0.65	1.01	3	1
ARP6PR3203SA32M	★		6.0	32	32	150	70	0.94°	2.0°	1.0	0.60	0.76	3	1
ARP6PR4004SA32M	★	6	6.0	32	40	150	50	—	2.7°	2.5	1.15	0.85	4	2
ARP6PR5005SA42M	★		6.0	42	50	150	50	—	2.9°	2.5	1.70	1.47	5	2
ARP6PR3202SA32L	★		6.0	32	32	200	120	0.52°	2.0°	1.0	0.60	1.00	2	1
ARP6PR4003SA32L	★		6.0	32	40	250	50	—	2.7°	2.5	1.15	1.48	3	2
ARP6PR5004SA42L	★		6.0	42	50	250	50	—	2.9°	2.5	1.70	2.53	4	2



SPARE PARTS

Tool holder number	*				
	Insert screw	Wrench	Anti-seize lubricant	Coolant nozzle	Insert
ARP5	TPS351B	TIP10D	MK1KS	HSD04004H	RPMT1040M0E4-o
ARP6	TPS4	TIP15D	MK1KS	HSD04004H	RPMT1248M0E4-o

* Clamp torque (N • m): TPS351B=2.5, TPS4=3.5

ARP5/6

INSERTS

M	Stainless steel	●	●			Cutting conditions: ●: Stable cutting ●: General cutting ✘: Unstable cutting	
S	Heat-resistant alloy, Titanium alloy			✘	✘	Honing: E: Round T: Chamfer	

Order number	Class	Honing	MC7020	MP7130	MP9130	MP9140	IC	S	Geometry
			●	●	●	●			
RPHT1040M0E4-L	H	E	●	●	●		10	3.97	
RPHT1248M0E4-L	H	E	●	●	●		12	4.76	
RPHT1040M0E4-M	H	E	●	●	●		10	3.97	
RPHT1248M0E4-M	H	E	●	●	●		12	4.76	
RPHT1040M0E4-R	H	E	●	●	●		10	3.97	
RPHT1248M0E4-R	H	E	●	●	●		12	4.76	
RPMT1040M0E4-L	M	E	●	●	●		10	3.97	
RPMT1040M0E4-L2	M	E				●	10	3.97	
RPMT1040M0E8-L1	M	E	●	●	●	●	10	3.97	
RPMT1248M0E4-L	M	E	●	●	●		12	4.76	
RPMT1248M0E4-L2	M	E				●	12	4.76	
RPMT1248M0E8-L1	M	E	●	●	●	●	12	4.76	
RPMT1040M0E4-M	M	E	●	●	●		10	3.97	
RPMT1040M0E4-M2	M	E				●	10	3.97	
RPMT1040M0E8-M1	M	E	●	●	●	●	10	3.97	
RPMT1248M0E4-M	M	E	●	●	●		12	4.76	
RPMT1248M0E4-M2	M	E				●	12	4.76	
RPMT1248M0E8-M1	M	E	●	●	●	●	12	4.76	
RPMT1040M0E4-R	M	E	●	●	●		10	3.97	
RPMT1040M0E8-R1	M	E	●	●	●		10	3.97	
RPMT1248M0E4-R	M	E	●	●	●		12	4.76	
RPMT1248M0E8-R1	M	E	●	●	●		12	4.76	

ARP5/6

RECOMMENDED CUTTING CONDITIONS

DRY CUTTING

Material	Hardness	Grade	Vc	fz
Austenitic stainless steel	≤200HB	MC7020	220 (170–270)	0.2 (0.1–0.35)
		MP7130	200 (150–250)	0.2 (0.1–0.35)
	>200HB	MC7020	190 (140–240)	0.2 (0.1–0.35)
		MP7130	170 (120–220)	0.2 (0.1–0.35)
Two-phase stainless steel	≤280HB	MC7020	180 (130–230)	0.2 (0.1–0.35)
		MP7130	160 (110–210)	0.2 (0.1–0.35)
Ferritic and martensitic stainless steel	≤200MPa	MC7020	240 (190–290)	0.2 (0.1–0.35)
		MP7130	200 (150–250)	0.2 (0.1–0.35)
	>200HB	MC7020	240 (190–290)	0.2 (0.1–0.35)
		MP7130	200 (150–250)	0.2 (0.1–0.35)
	<450HB	MC7020	170 (120–220)	0.2 (0.1–0.35)
		MP7130	150 (100–200)	0.2 (0.1–0.35)

WET CUTTING

Material	Hardness	Grade	Vc	fz	
Austenitic stainless steel	≤200HB	MC7020	150 (100–200)	0.2 (0.1 –0.35)	
		MP7130	130 (80–180)	0.2 (0.1 –0.35)	
	>200HB	MC7020	120 (70–170)	0.2 (0.1 –0.35)	
		MP7130	100 (80–150)	0.2 (0.1 –0.35)	
Two-phase stainless steel	≤280HB	MC7020	120 (70–170)	0.2 (0.1 –0.35)	
		MP7130	100 (80–150)	0.2 (0.1 –0.35)	
Ferritic and martensitic stainless steel	≤200MPa	MC7020	170 (120–220)	0.2 (0.1 –0.35)	
		MP7130	130 (80–180)	0.2 (0.1 –0.35)	
	>200HB	MC7020	170 (120–220)	0.2 (0.1 –0.35)	
		MP7130	130 (80–180)	0.2 (0.1 –0.35)	
	<450HB	MC7020	110 (60–160)	0.2 (0.1 –0.35)	
		MP7130	90 (50–140)	0.2 (0.1 –0.35)	
Titanium alloy	—	MP9130	45 (30– 55)	0.1 (0.05–0.15)	
		MP9140	40 (30– 50)	0.1 (0.05–0.15)	
		Heat resistant alloy	MP9130	35 (15– 45)	0.1 (0.05–0.15)
			MP9140	30 (15– 40)	0.1 (0.05–0.15)

- Actual cutting conditions are estimated to avoid chatter and vibration when used on stable applications.
Make appropriate adjustments when chatter or insert chipping occurs during machining.
Use with lower conditions for long overhang applications or when pocket machining.
- On workpiece entry, reduce the feed by 70 %. For ramping, drilling and plunging, reduce by 50 %.
- Internal coolant is recommended for titanium alloy and heat resistant alloy machining.

ARP5/6

CORRECTION RATIO (F) BASED ON THE (AP) AXIAL CUTTING DEPTH

Holder	ap = 0.5mm	ap = 1mm	ap = 1.5mm	ap = 2mm	ap = 2.5mm	ap = 3mm	ap = 3.5mm	ap = 4mm	ap = 5mm	ap = 6mm
ARP5	2.3	1.5	1.2	1.1	1.0	0.9	0.8	0.8	0.8	—
ARP6	2.5	1.7	1.3	1.1	1.0	1.0	0.9	0.9	0.8	0.8



GERMANY

MMC HARTMETALL GMBH
Comeniusstr. 2 . 40670 Meerbusch
Phone +49 2159 91890 . Fax +49 2159 918966
Email admin@mmchg.de

U.K.

MMC HARDMETAL U.K. LTD.
Mitsubishi House . Galena Close . Tamworth . Staffs. B77 4AS
Phone +44 1827 312312 . Fax +44 1827 312314
Email sales@mitsubishicarbide.co.uk

SPAIN

MITSUBISHI MATERIALS ESPAÑA, S.A.
Calle Emperador 2 . 46136 Museros/Valencia
Phone +34 96 1441711 . Fax +34 96 1443786
Email comercial@mmevalencia.es

FRANCE

MMC METAL FRANCE S.A.R.L.
6, Rue Jacques Monod . 91400 Orsay
Phone +33 1 69 35 53 53 . Fax +33 1 69 35 53 50
Email mmfsales@mmc-metal-france.fr

POLAND

MMC HARDMETAL POLAND SP. Z O.O
Al. Armii Krajowej 61 . 50-541 Wrocław
Phone +48 71335 1620 . Fax +48 71335 1621
Email sales@mitsubishicarbide.com.pl

RUSSIA

MMC HARDMETAL 000 LTD.
Electrozavodskaya St. 24 . build. 3 . Moscow . 107023
Phone +7 495 725 58 85 . Fax +7 495 981 39 79
Email info@mmc-carbide.ru

ITALY

MMC ITALIA S.R.L.
Viale Certosa 144 . 20156 Milano
Phone +39 0293 77031 . Fax +39 0293 589093
Email info@mmc-italia.it

TURKEY

MMC HARTMETALL GMBH ALMANYA - İZMİR MERKEZ ŞUBESİ
Adalet Mahallesi Anadolu Caddesi No: 41-1 . 15001 35580 Bayraklı/İzmir
Phone +90 232 5015000 . Fax +90 232 5015007
Email info@mmchg.com.tr

www.mitsubishicarbide.com | www.mmc-hardmetal.com

DISTRIBUTED BY:

□

□

└

└

Order Code: B222E 

Published: 2020.10 (0), Printed in Germany